

Finfloor

Laminate flooring installation and
maintenance instructions

Ensure all work follows NZS AS 1884:2013 and relevant NZ Building Code requirements, including the current performance requirements of Clause E3 Internal Moisture. Finfloor Laminate flooring complies with E3 as an alternative solution.

Disclaimer: Failure to adhere to these installation instructions may void the warranty, especially if such failure leads to product damage or performance issues. Please refer to the official warranty document for detailed terms and conditions.

01

Materials and tools

Glue is not needed to lay Finfloor laminate flooring, this makes the installation process easier and quicker.

- List of tools required: Saw, jigsaw, 50mm PVC tape, tape measure, pencil, spirit level, Stanley knife, tapping block and hammer.
- List of materials required: Flooring, underlay, profiles and skirting, separating wedges.

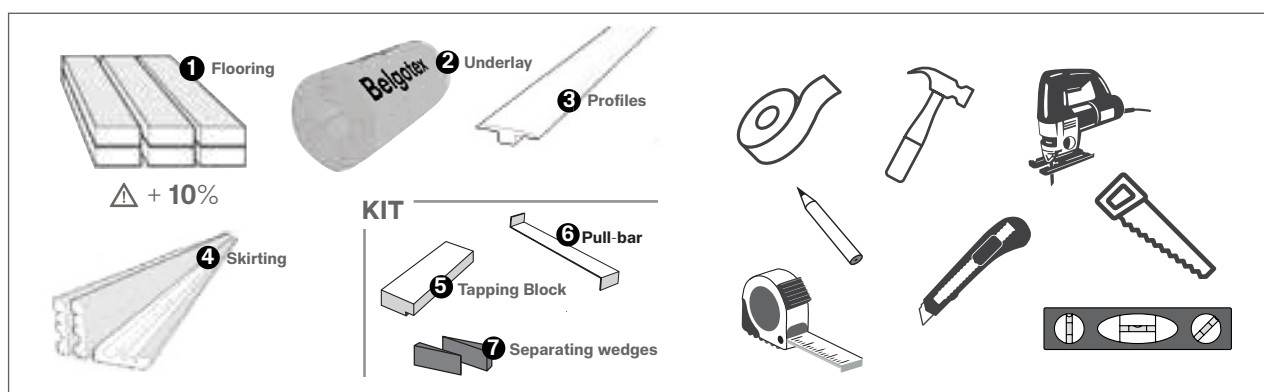

Recommended



Recommended



Don't do this



Invalidates Warranty

02

Pre-installation preparation

Finfloor is extremely versatile and can be installed in all areas of your home, except for areas with higher levels of humidity in the environment, such as saunas, where its use is not recommended.

Please read **Section 10** regarding Installing laminate flooring in **kitchens, laundry, toilets** and **bathrooms**.

The product needs to be acclimatized 48 hours prior to use with the boxes unopened and stored horizontally, well away from any walls.

The room temperature should be around 15°C - 25°C and the humidity between 50%-70% (the same as the room where it is going to be installed). While the product is stabilizing, do not open the boxes or lean them against a wall, and do not leave any floor boards out. Before installing Finfloor, ensure that the base floor is clean and dry, and check that the surface conditions on which the flooring is going to be laid are optimal. If there are any uneven areas of more than 2mm/linear metre, level them out in advance with a levelling compound system. Eliminate any irregularities which might reduce maximum surface contact between the floor board and the subfloor.

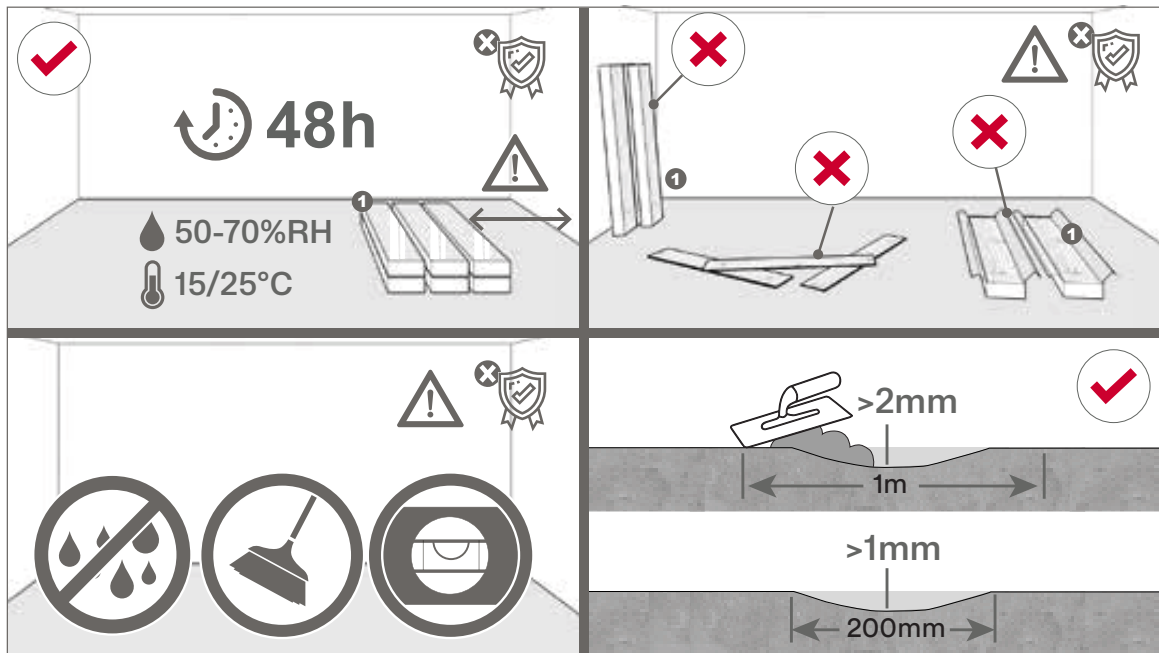

03

Suitable subfloors and preparation

Finfloor can be fitted directly on most existing floors (e.g. wood, PVC, concrete floors etc.) as long as the correct subfloor preparation is undertaken

A. Cement/concrete floors. The substrate should have a relative humidity level of less than 75%RH (Using the insitu probe test as outlined in NZS AS 1884-2013). When using artificial drying methods, sometimes only the surface layers dry and the lower layers can retain moisture which will, in time, rise to the surface. You should allow a sufficient period of time before taking new measurements to avoid any errors in the measurements taken. The drying time of the subfloor will depend on its thickness and the atmospheric conditions of the area. As a guide, you can estimate that in conditions of between 20°C and 50% relative humidity, drying time can be calculated using the following formula: $t = 2s^2$ where “t” is the time in days and “s” is the thickness of the base floor in centimetres. While this drying guide is useful it is not intended to replace the best practice of conducting an in-situ moisture test as described in NZS AS 1884-2013.

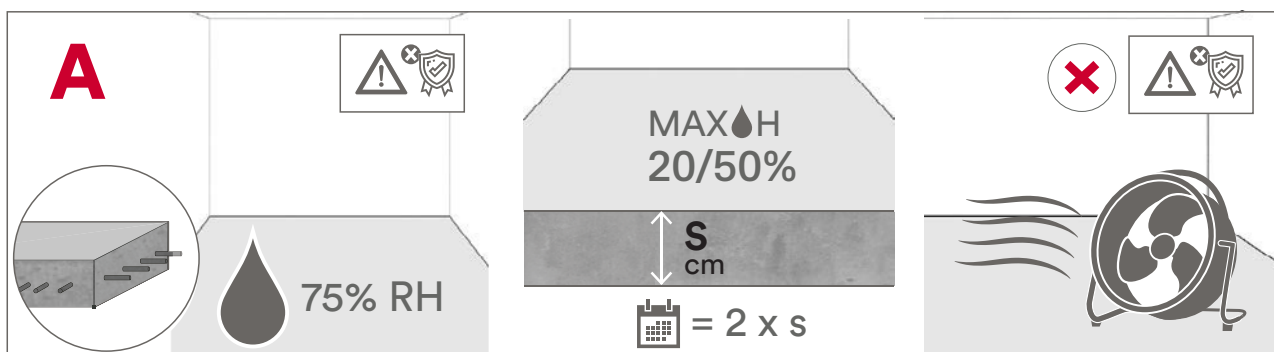

Note. Good subfloor preparation along with a quality underlay will ensure the performance of the laminate flooring. Underlay is intended for minor subfloor variation. For uneven areas of more than 2mm/linear metre, level them out in advance with a levelling compound system.

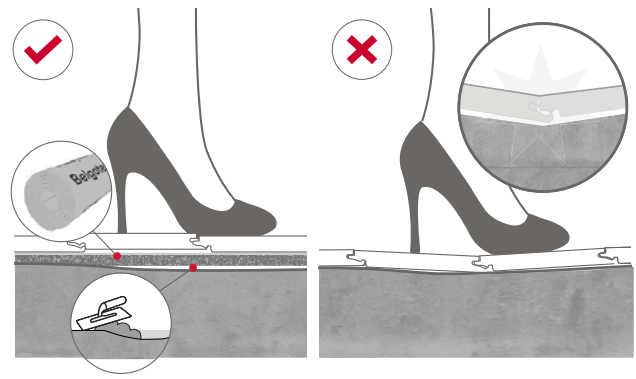

B. Floor boards. In this case, the flooring will be laid at 90° from the old flooring, never in the same direction as the old floor boards. It is important to ensure that there is adequate cross-flow ventilation underneath the dwelling and it should also be free of dampness.

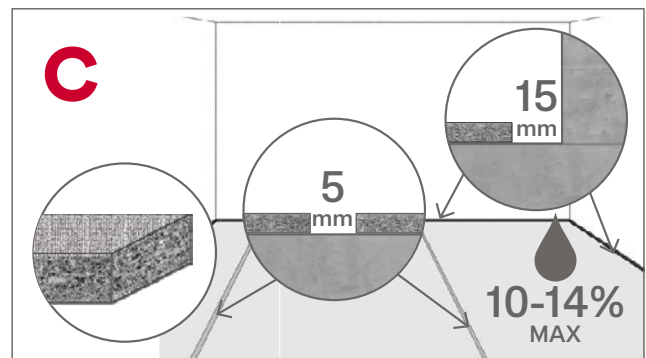
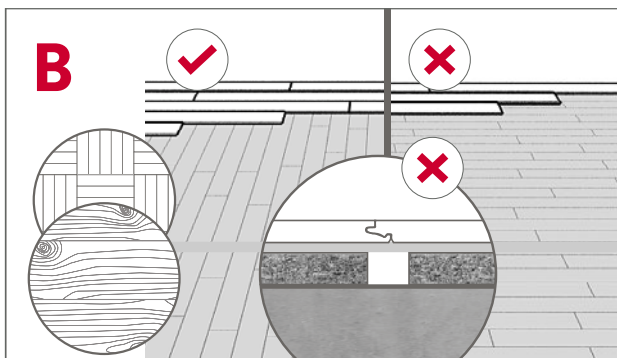

C. Ply or particle board. When laying flooring over ply or particle board or existing floor boards, you must leave enough space between the boards and the wall to allow for expansion (following the manufacturer's recommendations). The flooring must be laid so that the gaps between the old floor boards are not in the same place as the joints between the laminate floor boards. Wood or wood-based materials must have a moisture content of 10% – 14% when tested to methods described in NZS AS 1884:2013.

D. Carpet. In the case of carpet, you need to remove it (including the old glue) and make sure that the surface is stable and firm.

E. Under-floor heating. Finfloor laminate flooring can be laid over under-floor heating, following these instructions. See Section 11 "Installation in rooms with under-floor heating".

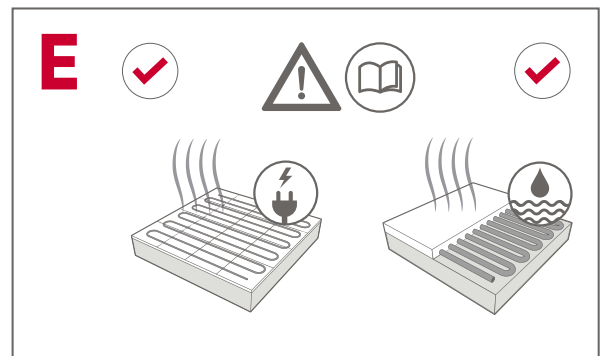
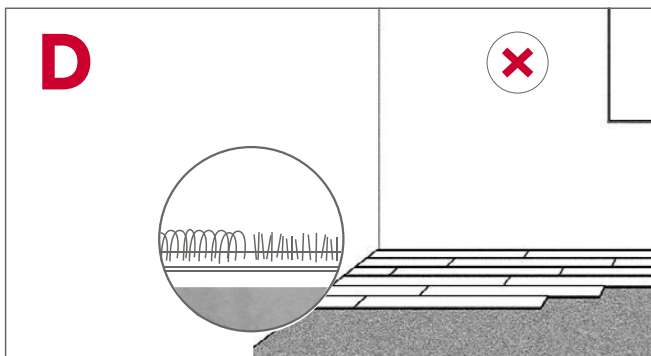

Underlay placement

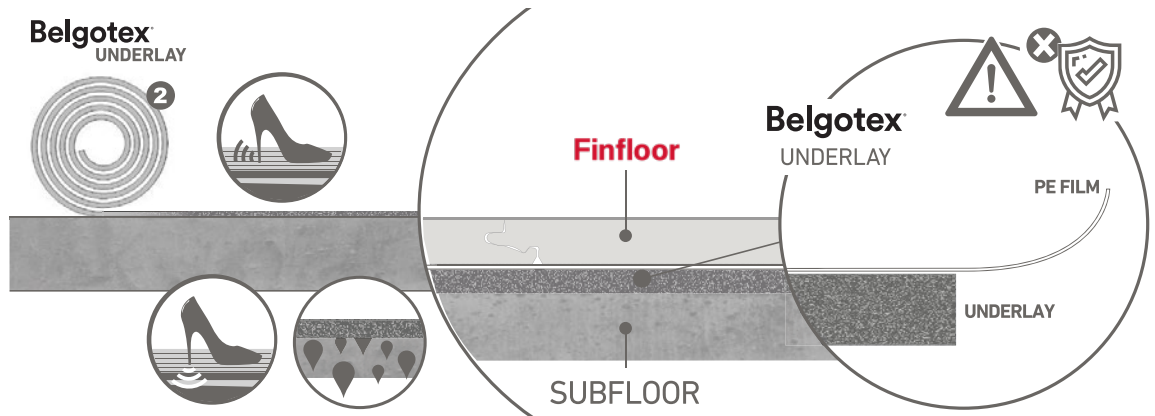

Moisture Protection for Concrete Subfloors

If a concrete subfloor exceeds 75% RH, an additional vapour barrier must be installed before laying the underlay. This vapour barrier should be 150-micron clear builder's plastic, with 300mm overlapped joints, fully sealed using a vapour-tight, waterproof tape. The plastic should be covered up the walls by 50mm and trimmed back after the underlay and laminate flooring have been installed.

If moisture testing is not performed, the subfloor should be assumed to have an RH above 75% and a vapour barrier should be installed.

For optimal performance, we recommend Belgotex Aqua Performance or Aqua Elite underlays. If using an alternative underlay, it must meet the following minimum specifications:

- Water Vapour Diffusion Resistance: \geq SD 75m
- Compression Strength (CS): \geq 40 kPa

Important:

Failure to install adequate subfloor moisture protection may void your warranty and result in product failure. Ensure all moisture mitigation measures comply with the specified requirements.

Belgotex offers different types of underlay in its accessories range that meet these levelling and insulation requirements.

Underlay should be installed plastic side facing upward and layed in the same direction as the floating floor. Laying at 90 degrees to the direction of the laminate flooring can cause the underlay to bunch up and overlap itself. TIP: Only 1-2 rows of underlay should be laid out at a time. As the laminate flooring is installed on top, it will compress the underlay, causing it to spread and shift. Belgotex underlay comes with an integrated vapour barrier with an integrated peel and stick tape.

The clear vapour barrier over hang should be overlapped over each following row in such a way as to create a continuous vapour barrier and it should be laid so that it covers the entire floor area and coves up the walls by 5-6 cm this will be cut when fitting the skirting board.

All underlay joins must be taped with a tape that effectively slows vapour transmission equal to or greater than 75m or equivalent to 200 micron builders plastic.

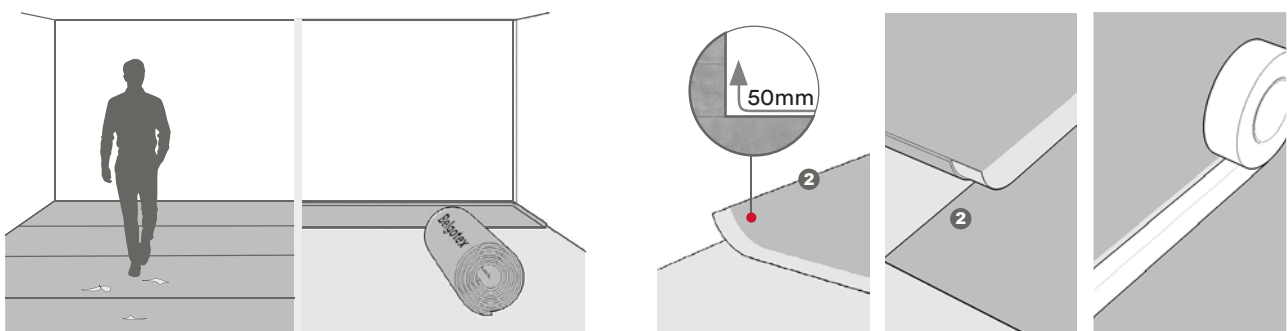

Orientation of the pieces

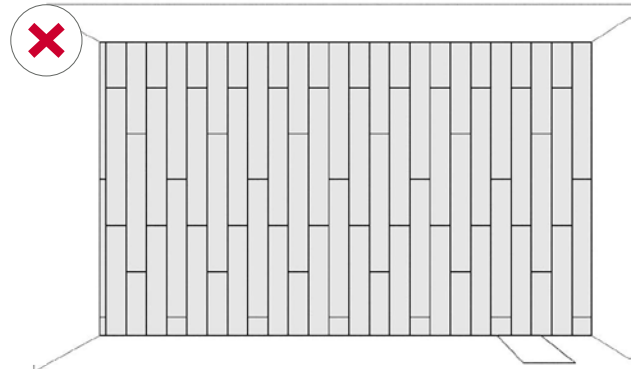
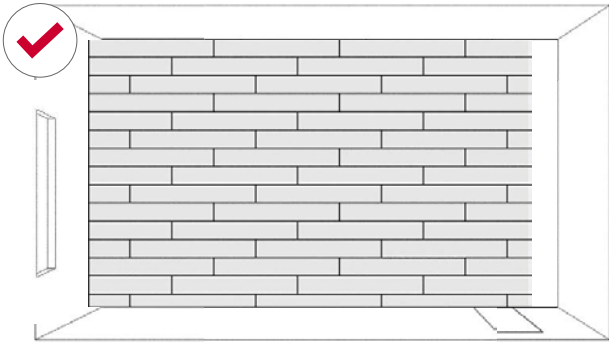

It is recommended to lay the flooring in the same direction as the main source of light.

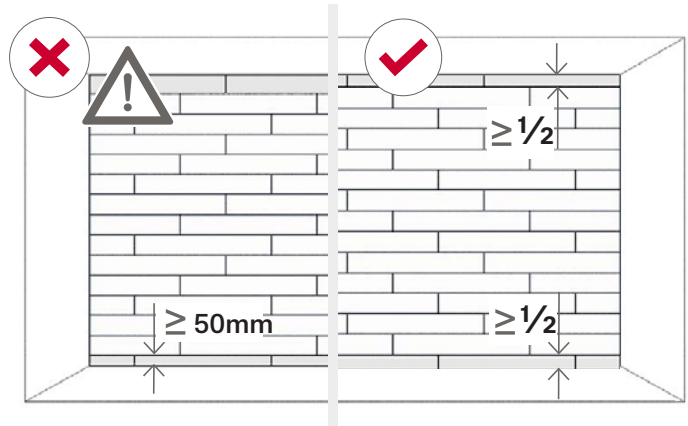
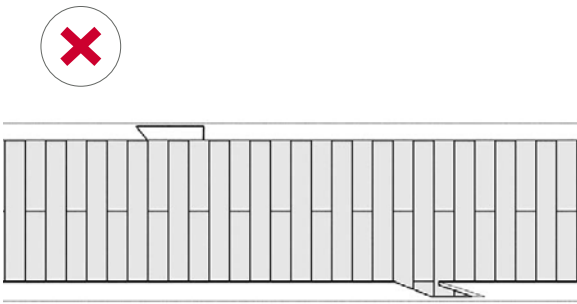

In corridors, it is preferable to be installed longitudinally. It is recommended to measure the room widthways, across the area where you are intending to lay the flooring, subtracting 20mm for the lateral expansion gaps. You then divide this figure by the width of a board in order to know how many rows of flooring you are going to need. The value of the decimal places multiplied by the total width will give you the size of the last board. If this figure is less than 50mm, you would have to cut back the first row of boards by approximately 10 cm to have enough width for the final row.

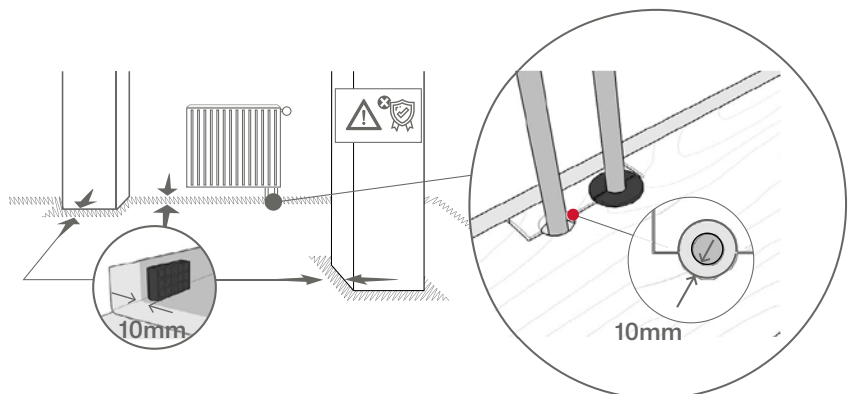
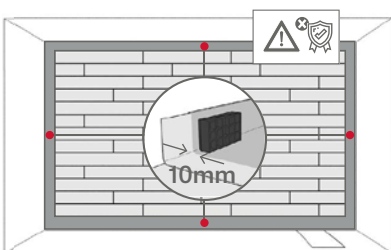

Expansion joints

A continuous expansion gap must be provided around the entire perimeter between your Finfloor laminate and all vertical surfaces. This gap will be hidden in the end with the skirting board and finishing profiles, and will give the product the space necessary for expansion and contraction. In the case of holes for pipes, measure the diameter of the pipe and make a hole 20 mm bigger. Cut a section with a saw as shown in the figure and put the board in place on the floor. Then lay the cut section in place like a jigsaw puzzle. Maximum flooring raft size should not exceed 13 metres in the width or the length. For large flooring rafts that exceed 13 metres in length or width or for multi-room dwellings, control joint/s should be installed.

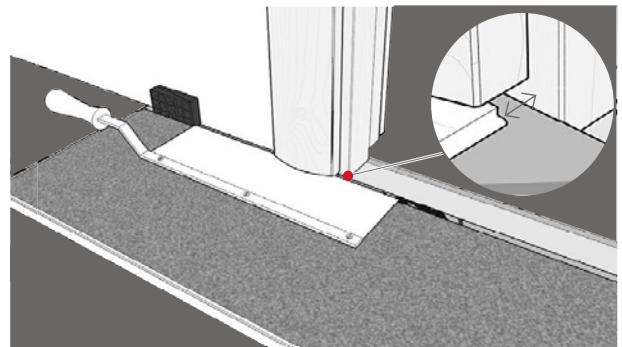
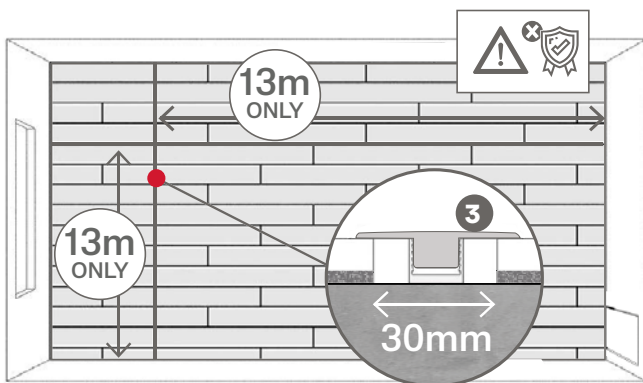

Door frames can be undercut to accommodate the floating floor to underneath them. Special care is required as 10 mm also needs to be left to allow for expansion.

Heavy furniture like bookcases, aquariums, slate pool tables, stone bench tops, kitchen cabinets can restrain the natural seasonal movement of your floor. In rooms that contain heavy furniture like these should be compartmentalised or the furniture should rest its weight on the subfloor and not the floating floor.

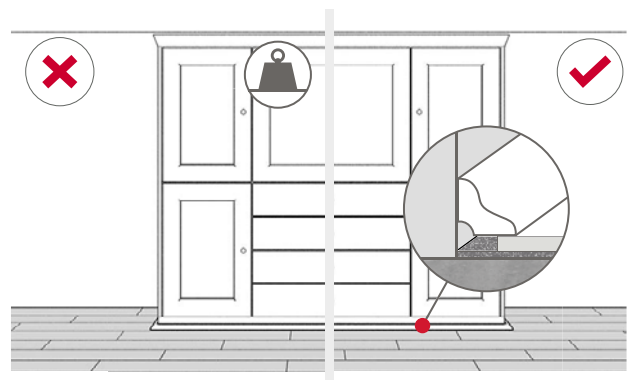
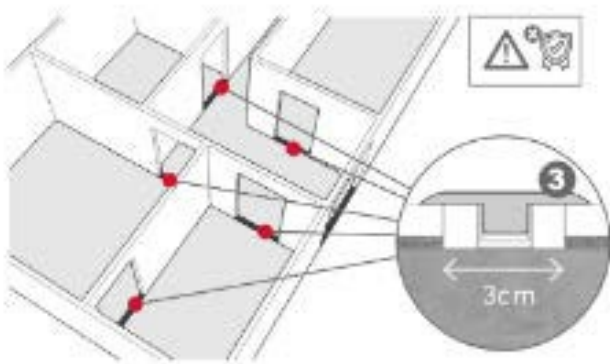

Installation of the flooring

- FIRST PIECES OF THE ROWS:

Start the first row with a full length board. Start the second row with a 1/3 length board and the third row with a 2/3 length board. After the first three rows you will need to randomly alternate the board lengths in order to achieve a random pattern throughout the floor. Ensure that end joints of adjacent row have a minimum spacing apart of 200mm but preferably 300mm or greater.

- FIRST PIECES OF THE FIRST ROW:

Start laying the flooring from left to right, with the 'tongue' facing the wall. Make sure you place the boards 10 mm away from both walls. If the wall is irregular, the boards will need to be adapted to the contour of the wall.

This is easier to do if you lay three rows of boards first, then, after cutting them to the shape of the wall, push them nearer to the wall to adapt them to its irregularities, maintaining said gap of 10 mm along the entire contour.

- LOCK IN THE SHORT END OF THE SECOND PIECE:

Place the short ends of the two pieces together (trying to leave them lined up straight), lift the piece at an angle of 15°-20°, pushing lightly forwards and downwards so that the piece automatically hooks into the adjoining piece. Continue this process until the row is finished. Place the last board, turning it 180° and facing it on the short sides groove to groove.

Place the separating wedge (10 mm) between the wall and the piece and mark the area where it crosses the previous piece to cut it. If this is difficult, measure the distance with a tape measure and don't forget to subtract the 10mm expansion gap.

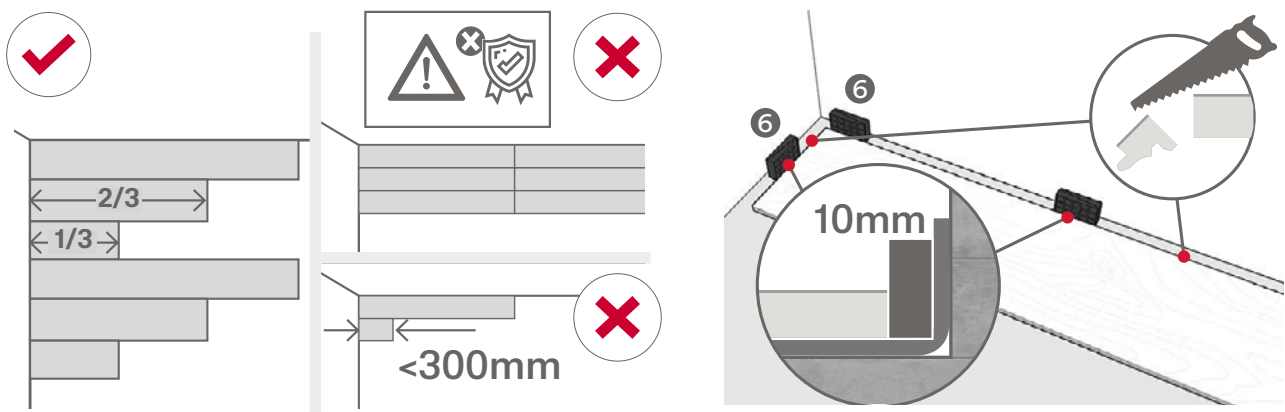

- CUTTING THE BOARDS:

While a handsaw can be used, a drop saw is a great way to get the job done quickly. The saw blade diameter will dictate how many teeth the blade should have. A 254mm diameter saw blade should have at least 40 teeth. If using a drop saw, boards can be cut decor facing upwards. If using a jigsaw, blades can be purchased from your local hardware store that are designed for cutting laminate and on the downward stroke.

- FIRST PIECE OF THE SECOND ROW:

Use a section of the board cut in the previous row. This section must be at least 200mm long. If it is too short, start the row with a new board cut to 1/3 the length of the piece. Always make sure that the joints at the ends are staggered at least 300mm.

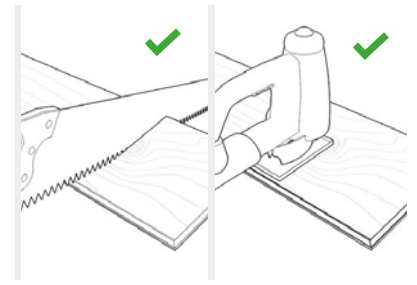

- CONTINUE LAYING THE FLOORING:

1. Place the piece flat, parallel to the board of the adjoining row, raise the board at an angle ($\pm 15^\circ$), push forwards and down lightly and the pieces should automatically interlock.
2. Place the short end of the board at an angle opposite the board just installed, push forwards and down lightly. Make sure that the board lengthways along the piece is close to the adjoining board, and lock it together with the previous piece.
3. Lift the board $\pm 15^\circ$ (along with the previous board laid in the same row), push lightly forwards and down, sliding the piece so it can lock into the length sides of the previous piece.

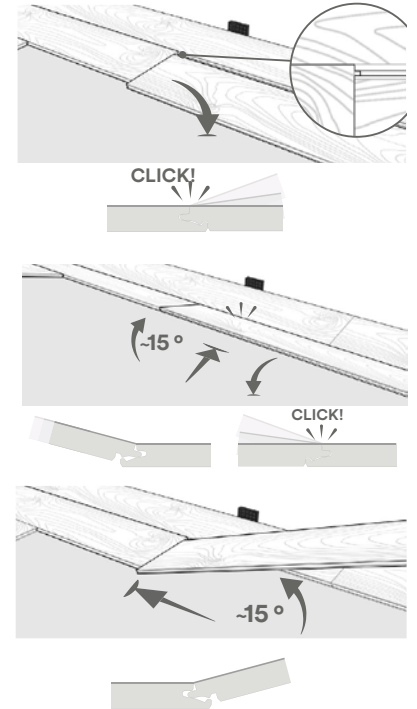

- LAYING THE FINAL ROW:

Measure and cut the board. Leave 10 mm from the wall for the necessary expansion gap.

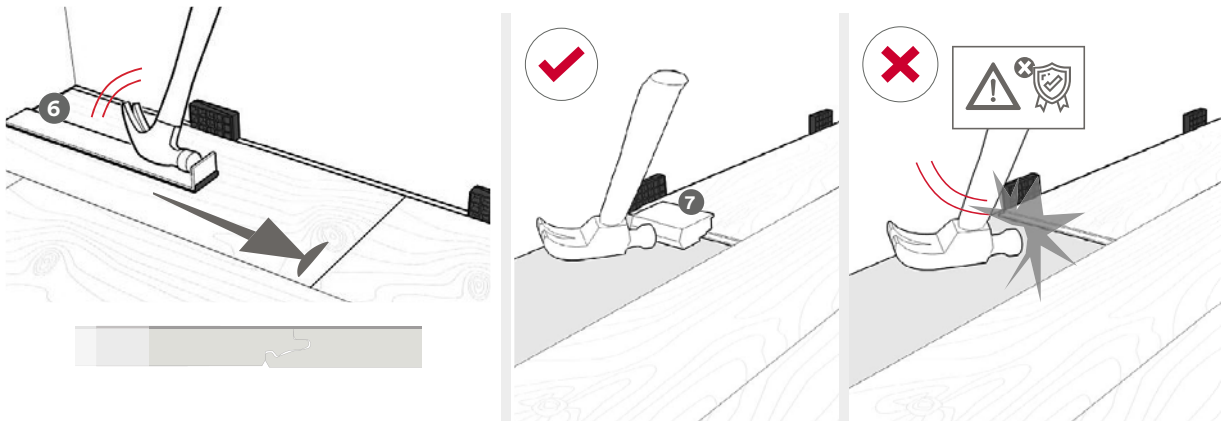

ATTENTION: In some circumstances, it is not possible to lift the boards at an angle so they lock together (for example, underneath door frames or radiators etc.). In such cases, you can horizontally engage pieces together with the boards laying flat, rubber mallets should not be used to strike the surface of the laminate as this can permanently damage and alter the surface sheen or damage locking system. A block of wood with attached double sided tape can be a suitable aid in pulling or pushing horizontal boards together. Tap the pieces gently until they lock together, taking care not to damage the laminate, and making sure that the Installation Kit hitting block is in uniform contact with the edge of the laminate flooring. Do the same on the long side, but starting progressively at an end to move forward the length of the piece. Boards with damage to the locking system should not be installed into floor as this can compromise the structural integrity of the joint.

To prevent damaging the locking system while using the pull-bar, a sacrificial off-cut can be used to lock into the side.

Skirting boards and profiles

To fit the expansion profile, you should leave a 30 mm gap (10 mm for the width of the clips and 10 mm for each length, note that the base of the profile is asymmetric, although this does not affect the spaces for expansion) where the expansion profiles will be placed to separate the different rooms. To maintain the integrity of a floating floor, avoid applying silicone where the flooring meets skirting boards or vertical surfaces, as this can restrict the floor's natural movement. Notably, a gap between the skirting board and the floating floor is not necessary. Avoid painting the bottom of skirting boards as the paint can be very tacky and form a strong bond to the floating floor.

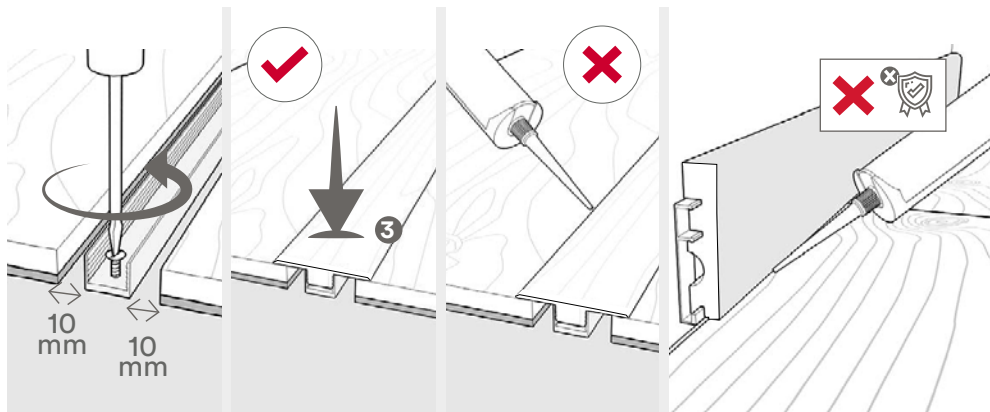

E3 dictates the use of silicone around skirting boards, end panels, cabinets, kickers etc. 1.5 metres from sanitary fixtures or appliances. Specifically in this case, a low modulus silicone is permissible in order to comply with E3 but may necessitate the need for extra control joints or re-calculation of expansion gaps to accommodate for the floor which may only expand or contract in one direction. In this case it is ok but this means that there is a greater need for controls joints. Failure to use a low modulus silicone may void your warranty.

Maintenance and cleaning

The surface of Finfloor flooring is protected for a long life and high wear resistance. The product is sold finished and does not need any work done on it. However, there are a number of recommendations and instructions to follow to maintain and clean it.

- The ideal conditions for avoiding problems with the boards' dimensions and static loads are: 50-70% RH and 20°C. Use a humidifier if needed.
- Do NOT varnish, sand, polish etc. the laminate flooring. Products with wax, citrus or eucalyptus oil, soap or polish may leave behind residues. Do NOT wash microfibre mop in a washing machine that's used fabric softener as this will permanently clog the microfibers and subsequently the mop will spread the fabric softener across the floor surface causing greasy footprints to become more obviously visible.
- Never fix the laminate flooring to the subfloor or other construction elements (with glue, nails, fixed door stops etc).
- Protect the feet of furniture and chairs with felt or plastic pads and regularly check their condition and cleanliness.
- Use chairs with soft wheels that won't damage the flooring (Type W, in accordance with regulation DIN 68131), or failing that, use a polycarbonate mat to avoid direct contact with the floor (the wheels should be kept clean).
- The use of doormats at exterior door entrances is recommended in order to prevent dirt, dust, gravel, water etc. coming in from the street.
- Use a broom, cleaning pad, vacuum cleaner with brush for veneer flooring or a completely wrung out mop. Never use abrasive cleaning aids (wire wool, scouring pads etc.) or cleaning machines to clean the laminate flooring.
- Use non-abrasive pH neutral detergents.
- To clean grooved products, do not use sharp or pointed, abrasive, cutting, wet etc. instruments. Use a vacuum cleaner with a brush for parquet flooring. If this is not enough, use a cloth slightly dampened in water.
- To eliminate stubborn stains on the surface (NEVER in joints or groves), use slightly diluted acetone or alcohol for household use. Clean with water afterwards.
- Special care should be taken in areas with pets (urine can damage the laminate flooring; avoid it and clean it immediately).
- Any water spills must be wiped up within 24 hours.

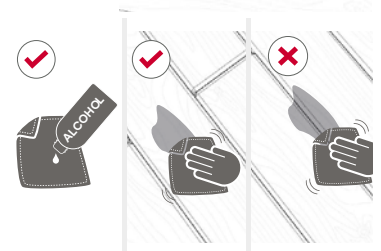
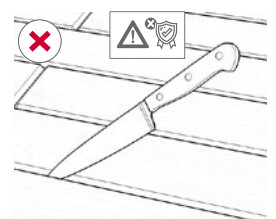
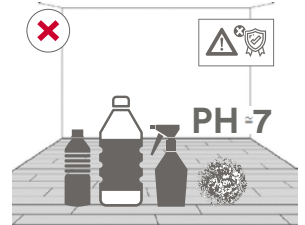
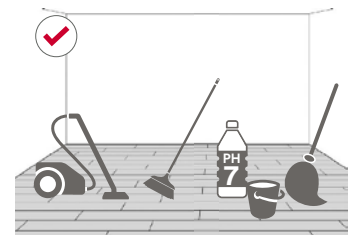
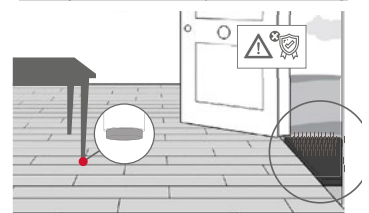

Installing laminate flooring in kitchen, laundry, bathroom and toilets

The use of joint sealers is not required for installation in wet or splash-prone areas such as kitchens, bathrooms, laundries, or toilets, however their use in toilets is recommended as best practice to provide extra protection against urine.

If desired, the addition of Finsa joint sealer can be applied. Always follow the manufacturer's specifications and local Building Code requirements.

DIRECTION FOR USE (where joint sealer is specified for use):

1. The sub-floor must be clean, dry and free of dust and grease.
2. Before assembling the boards, apply a continuous line along the length and width of the tongue edges of each board.
3. Join the two boards immediately. For a correct seal, the product should overflow from the joint.
4. Leave to dry for 15 to 30 minutes and then remove the excess product using a putty knife.

PERIMETER APPLICATION SILICONE

Finfloor low modulus clear silicone in conjunction with foam backer rod is designed to prevent water filtering under floating floors in kitchens and bathrooms. Ideal for filling the expansion gaps between the floating flooring and walls, furniture and bathroom fittings. The backer rod prevents the over filling of the expansion gap allowing greater ease of seasonal movement. The high degree of elasticity permits the flooring to expand without losing adherence on building materials, such as concrete, cement, brick, natural stone, metals, wood, fibre glass, PVC and glass. For all Finfloor collections, application of Finsa perimeter silicone is required for bathrooms and in relation to E3 is required up to 1.5 metres from sanitary appliances and fixtures which may include kitchens, laundries and toilets.

DIRECTION FOR USE:

1. Surfaces must be clean and dry.
2. Apply with a sealant gun between +5°C and +40°C.
3. Apply the silicone over the foam backer rod that has been inserted into the expansion gap. Ensure there is a sufficient application of silicone to continuously and completely cover the foam rod and between the floating floor and the wall, toilet, pipe, etc. in such a way that will stop water getting underneath the floating floor via the expansion gaps. Around door frames backer rod is not required. If the filler/sealant overflows slightly on the floor, it will be hidden later by the skirting board. A foam backer rod is not required underneath door frames or architraves, a bead of silicone is sufficient.
4. Smooth with a putty knife or a wet, soapy finger.
5. Allow 24hrs for drying for every 3mm depth of silicone.

**Installation in toilets,
bathrooms and kitchens.**

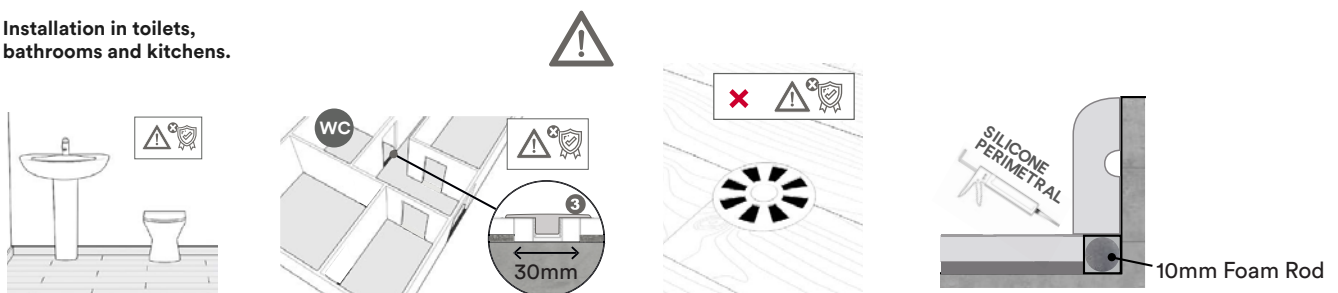

Installation in rooms with under-floor heating

Finfloor is suitable for rooms with hydronic under-floor cooling/heating systems or electric foil.

To use underlay and flooring over under-floor heating, the total thermal resistance must not be $> 0.15 \text{ (m}^2\cdot\text{K)/W}$.

The values obtained for the Belgotex Underlay and joint solution are $0.127 \text{ (m}^2\cdot\text{K)/W}$. It is also essential to respect the following installation rules and protocols:

When the under-floor heating system has been installed.

1. The concrete subfloor should be less than 75%RH. If it is higher, wait until this value is reached.
2. Start heating until reaching a surface temperature of 18°C , which will be maintained for 3 days.
3. Condition the unopened boxes of materials during those 3 days in the room where the flooring will be laid.
4. Start laying the flooring, keeping the base floor temperature at around 18°C .
5. After the flooring has been laid, maintain the same temperature for another 3 days.
6. After that time, gradually increase the temperature by 2°C per day. The subfloor temperature (contact temperature) must not exceed 29°C or 65W/m^2 if it is an electrical system. The heat must be distributed homogeneously across the entire floor to prevent any cold or warm zones.

The heat radiates up and not down!

The maximum surface temperature is not more than 29°C .

The electrical connectors between the panels must be thin enough to be embedded in the underlay mat while maintaining their strength and electrical safety, also in the event of possible condensation or a leak.

Using large rugs can heat the area under them, which is detrimental to laminate flooring.

The ideal room temperature is 20°C air temperature, with 50-70% relative humidity. In very dry situations, it is advisable to use a humidifier to raise the relative humidity.

Operation of the heating system must start low and incrementally increased by 2 degrees each day. NEVER SUDDENLY to avoid damaging the flooring.

It is recommended for the skirting not to be installed until completing the heating and cooling sequence in order to check that the perimeter joints are correct after the flooring has moved in the different conditions.

Finfloor